

	<h1>TARAtec P10.1</h1>
Indicator	Peracetic acid
Application	<p>All kinds of water treatment, also sea water Conductivity acids are tolerated. (e. g. bottle washing machine, CIP-plants) The membrane system is mechanical resistant. The membrane system is highly resistant to surfactants (tensides).</p>
Measuring system	Membrane covered, amperometric 2-electrode system
Electronics	<p>Analog version: - voltage output - not galvanically isolated electronics - analog internal data processing - output signal: analog (analog-out/analog)</p> <p>Digital version: - electronic is completely galvanically isolated - digital internal data processing - output signal: analog (analog-out/digital) or digital (digital-out/digital)</p> <p>mA-version: - current output analog - not galvanically isolated electronics - output signal: analog (analog-out/analog)</p>
Information about the measuring range	<p>The actual slope of a sensor can vary production-related between 65% and 150% of the nominal slope</p> <p>Note: With a slope > 100% the measuring range is reduced accordingly. (Ex.: 150% slope → 67% of the specified measuring range)</p>
Accuracy After calibration at repeat conditions (25 °C, in drinking water) from full scale value	<p>Measuring range 2000 mg/L: at 400 mg/l <2% at 1600 mg/l <3%</p>
Working temperature	Measuring water temperature: 0 ... +45 °C (no ice crystals in the measuring water)
	Ambient temperature: 0 ... +55 °C
Temperature compensation	<p>Automatically, by an integrated temperature sensor sudden temperature changes must be avoided Response time t_{90}: approx. 8 min.</p>
Max. allowed working pressure	<p>Operation without retaining ring:</p> <ul style="list-style-type: none"> - 0.5 bar - no pressure impulses and/or vibrations
	<p>Operation with retaining ring in TARAflow FLC:</p> <ul style="list-style-type: none"> - 1.0 bar, - no pressure impulses and/or vibrations (see option 1)

	<h1>TARAtec P10.1</h1>	
<p>Flow rate (Incoming flow velocity)</p>	<p>approx. 15-30L/h (33 – 66 cm/s) in TARAflow FLC, small flow rate dependence is given</p>	
<p>pH-range</p>	<p>pH 1 – pH 8 (see Diagram “Slope of TARAtec P9.3 and P10.1 versus pH“, page 8)</p>	
<p>Run-in time</p>	<p>Measuring range 200 mg/L: First start-up approx. 3 h Measuring range 2000 mg/L: First start-up approx. 1 h Measuring range 20000 mg/L: First start-up approx. 30 min.</p>	
<p>Response time</p>	<p>T₉₀: approx. 3.5 min. at 10 °C T₉₀: approx. 1.5 min. at 45 °C</p>	
<p>Zero point adjustment</p>	<p>Not necessary</p>	
<p>Calibration</p>	<p>At the device, by analytical determination</p>	
<p>Interferences</p>	<p>O₃: increases the measured value strongly ClO₂: increases the measured value H₂O₂: very low influence on the measuring value (reduction of the PAA-signal)</p>	
<p>Influence of conductivity acids</p>	<p>1 % sulfuric acid, 1 % nitric acid or 1 % phosphoric acid in the water have no influence to the measuring behaviour</p>	
<p>Absence of the disinfectant</p>	<p>Max. 24 h</p>	
<p>Connection</p>	<p>mV version: 5-pole M12, plug-on flange Modbus version: 5-pole M12, plug-on flange 4-20 mA version: 2-pole terminal or 5-pole M12, plug-on flange</p>	
<p>Max. length of sensor cable (depending on internal signal processing)</p>	<p>analog</p>	<p>< 30 m</p>
	<p>digital</p>	<p>> 30 m are permissible Maximum cable length depends on application</p>
<p>Protection type</p>	<p>5-pole M12 plug-on flange: IP68 2-pole terminal with mA-hood: IP65</p>	
<p>Material</p>	<p>Elastomer membrane, PVC-U, stainless steel 1.4571</p>	
<p>Size</p>	<p>diameter: approx. 25 mm Length: mV version approx. 190 mm (analog signal processing) approx. 205 mm (digital signal processing) Modbus version approx. 205 mm 4-20 mA version approx. 220 mm (2-pole-terminal) approx. 190 mm (5-pole-M12)</p>	
<p>Transport</p>	<p>+5 ... +50 °C (Sensor, electrolyte, membrane cap)</p>	

	<h1>TARAtec P10.1</h1>
<p>Storage</p>	<p>Sensor: dry and without electrolyte no limit at +5 ... +40 °C</p> <p>Electrolyte: in original bottle protected from sunlight at +5 ... +35 °C min. 1 year or until specified EXP-Date</p> <p>Membrane cap: in original packing no limit at +5 ... +40 °C (used membrane caps cannot be stored)</p>
<p>Maintenance</p>	<p>Regular control of the measuring signal, min. once a week The following specifications depend on the water quality: Change of the membrane cap: once a year Change of the electrolyte: every 3 - 6 months</p>
	<p>EMC tested RoHS compliant</p>

<p>Option 1: Retaining ring</p>	<ul style="list-style-type: none"> - When operating with pressures >0.5 bar in TARAflow FLC - Dimensions retaining ring 29 x 23.4 x 2.5 mm, slitted, PETP - Different positions for groove selectable (on request) 	
--	--	--

Technical Data
1. P10.1 (Analog output, analog internal signal processing)

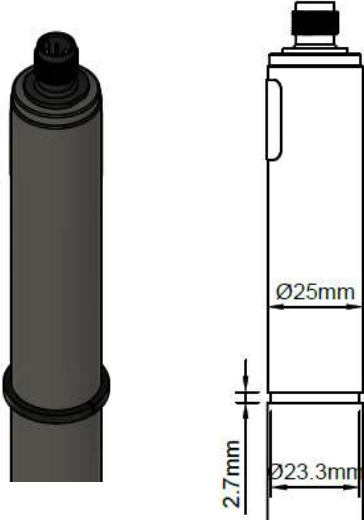
A potential-free electrical connection is necessary as the sensor electronic is not equipped with a galvanic.

	Measuring range	Resolution	Output Output resistance	Nominal slope	Voltage supply	Connection
P10.1-20-M12	0...20 ppm	0,01 ppm	0...-2000 mV 1 kΩ	-100 mV/ppm	±5 - ±15 VDC 10 mA	5-pole M12 plug-on flange Function of wires: PIN1: measuring signal PIN2: +U PIN3: -U PIN4: signal GND
P10.1H-M12	0...200 ppm	0.1 ppm		-10 mV/ppm		
P10.1N-M12	5...2000 ppm	1 ppm		-1 mV/ppm		
P10.1L-M12	0.005...2 % (20000 ppm)	0.001 % (10 ppm)		-1000mV/% (-0.1 mV/ppm)		
P10.1Up2000-M12	5...2000 ppm	1 ppm	0...+2000 mV	+1 mV/ppm	10 - 30 VDC	5-pole M12 plug-on flange Function of wires: PIN1: measuring signal PIN2: +U PIN3: power GND PIN4: signal GND PIN5: n. c.
P10.1Up5000-M12	50...5000 ppm	1 ppm	1 kΩ	+0.4 mV/ppm	10 mA	

(Subject to technical changes.)

2. P10.1 (analog output, digital internal signal processing)
 analog-out / digital

- The power supply is galvanically isolated inside of the sensor.
- The output signal is galvanically isolated too, that means potential-free.

	Measuring range	Resolution	Output Output resistance	Nominal Slope	Power supply	Connection		
P10.1-20- An-M12	0...20 ppm	0,01 ppm	analog 0...-2 V (max. -2.5 V)	-100 mV/ppm	9-30 VDC approx. 20-56 mA	5-pole M12 plug-on flange Function of wires: PIN1: measuring signal PIN2: +U PIN3: power GND PIN4: signal GND		
P10.1H-An-M12	0...200 ppm	0.1 ppm		-10 mV/ppm				
P10.1N-An-M12	5...2000 ppm	1 ppm		-1 mV/ppm				
P10.1L-An-M12	0.005...2% (20000 ppm)	0.001% (10 ppm)		-1000 mV/% (-0.1 mV/ppm)				
P10.1-20- Ap-M12	0...20 ppm	0,01 ppm	analog 0...+2 V (max. +2.5 V)	-100 mV/ppm				
P10.1H-Ap-M12	0...200 ppm	0.1 ppm		+10 mV/ppm				
P10.1N-Ap-M12	5...2000 ppm	1 ppm		+1 mV/ppm				
P10.1L-Ap-M12	0.005...2% (20000 ppm)	0.001% (10 ppm)		+1000 mV/% (+0.1 mV/ppm)				

(Subject to technical changes.)

3. P10.1 (digital output, digital internal signal processing)

- The power supply is galvanically isolated inside of the sensor.
- The output signal is galvanically isolated too, that means potential-free.

	Measuring range	Resolution	Output Output resistance	Power supply	Connection
P10.1-20- M0c	0...20 ppm	0,01 ppm	Modbus RTU There are no terminating resistors in the sensor.	9-30 VDC	5-pole M12 plug-on flange Function of wires: PIN1: reserved PIN2: +U PIN3: power GND PIN4: RS485B PIN5: RS485A
P10.1H-M0c	0...200 ppm	0.1 ppm			
P10.1N-M0c	5...2000 ppm	1 ppm			
P10.1L-M0c	0.005...2% (20000 ppm)	0.001% (10 ppm)			

(Subject to technical changes.)

4. P10.1 4-20 mA (analog output, analog internal signal processing)

A potential-free electrical connection is necessary as the sensor electronic is not equipped with a galvanic.

4.1 Electrical connection: 2 pole terminal clamp

	Measuring range	Resolution	Output Output resistance	Nominal slope	Voltage supply	Connection
P10.1MA20	0...20 ppm	0,01 ppm	4...20 mA uncalibrated	0,8 mA/ppm	12...30 VDC R _L = 50Ω (12V) R _L 900Ω (30V)	2-pole terminal (2 x 1 mm ²) Recommended: Round cable ∅ 4 mm
P10.1MA-200	0...200 ppm	0.1 ppm		0.08 mA/ppm		
P10.1MA-2000	5...2000 ppm	1 ppm		0.008 mA/ppm		
P10.1MA-5000	50...5000 ppm	1 ppm		0.0032 mA/ppm		
P10.1MA-2%	0.005...2 % (20000 ppm)	0.001 % (10 ppm)		8.0 mA/% (0.0008 mA/ppm)		
P10.1MA-5%	0.05...5 % (50000 ppm)	0.01 % (100 ppm)		3.2 mA/% (0.00032 mA/ppm)		

(Subject to technical changes.)

4.2 Electrical connection: 5 pole M12 plug-on flange

	Measuring range	Resolution	Output Output resistance	Nominal slope	Voltage supply	Connection
P10.1MA20-M12	0...20 ppm	0,01 ppm	4...20 mA uncalibrated	0,8 mA/ppm	12...30 VDC R _L = 50Ω (12V) ... R _L 900Ω (30V)	5-pole M12 plug-on flange Function of wires: PIN1: n. c. PIN2: +U PIN3: -U PIN4: n. c.
P10.1MA-200-M12	0...200 ppm	0.1 ppm		0.08 mA/ppm		
P10.1MA-2000-M12	5...2000 ppm	1 ppm		0.008 mA/ppm		
P10.1MA-5000-M12	50...5000 ppm	1 ppm		0.0032 mA/ppm		
P10.1MA-2%-M12	0.005...2 % (20000 ppm)	0.001 % (10 ppm)		8.0 mA/% (0.0008 mA/ppm)		
P10.1MA-5%-M12	0.05...5 % (50000 ppm)	0.01 % (100 ppm)		3.2 mA/% (0.00032 mA/ppm)		

(Subject to technical changes.)

Spare Parts

Type	Membrane cap	Electrolyte	Emery	O-ring
P10.1 not: - P10.1L - P10.1MA-2% - P10.1MA-5%	M10.3N Art. no. 11057	EPS9H/W, 100 ml Art. no. 11025	S2 Art. no. 11906	20 x 1.5 silicone Art. no. 11803
P10.1L P10.1MA-2% P10.1MA-5%		EPS9L/W, 100 ml Art. no. 11024		

(Subject to technical changes.)

Slope of TARAtec P9.3 and P10.1 versus pH

Temperature: 25°C / Flow rate: 30 L/h

